

MEGAFORM Boom Inspection Procedure

Models Affected: Grove and Grove GMK

This form was designed to establish a standard field procedure to check and inspect MEGAFORM style booms for squareness, sweep, twist, camber and flatness or convex / concave conditions.

This procedure pertains to Grove and GMK built MEGAFORM style booms.

This boom inspection data form will be used to record all measurements taken while performing the inspection.

Note: All calculations will be done by Manitowoc Product Support.

Note: Anytime you are using gauge blocks, record the thickness of the block used in the appropriate space on the form. Always use gauge blocks large enough to ensure the string does not touch the boom section. **All dimensions recorded must include the gauge block thickness.**

Tools Required

- Quantity 1 - 4 Foot Level
- Quantity 1 - Large Square (3' x 4')
- Quantity 2 - Small Squares (24" x 16")
- Quantity 2 - Vise Grip Clamps
- Quantity 1 - 6" scale
- Quantity 1 - 12' Tape Measure
- Quantity 2 - Gauge Blocks or Rods (Same Thickness and magnetic)
 - Mason String

Definitions

GMK Style / MEGAFORM - A six sided boom made from two formed channels. The top half has 90° bends and the bottom half has multiple bends.

Sweep - To curve to the right or left, a deviation from being parallel. The measured dimension is larger than the gauge block on one side and smaller than the gauge block on the other side.

Camber - To arch slightly, to curve upward or downward.

Squareness - To test for a deviation from a right angle.

Twist - To rotate while taking a curving path or direction.

Convex - Arched up or bulging out condition.

Concave - Arched inward or bulging in condition.

Distortion - To be deformed from the original shape.

Check Dimension - The actual measurements taken at various places on boom.

Gauge Blocks - Blocks, being the same size, from which measurements are being taken.

Serial Number and Part Number Locations on MEGAFORM Booms

Machine component serial numbers and part numbers are required for us to supply repair procedures for major weldments. Please be sure to record these numbers where specified on the inspections sheets.

The numbers are steel stamped into the boom section weldments in the approximate locations shown.

FRONT OF SECTION

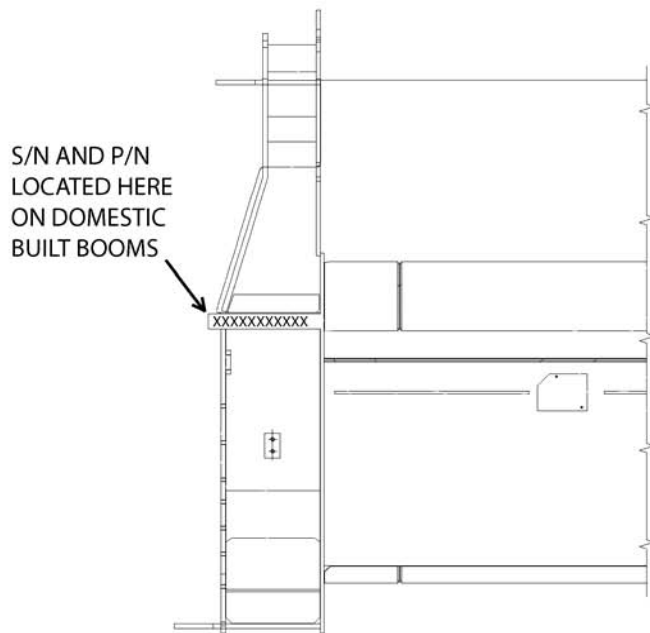
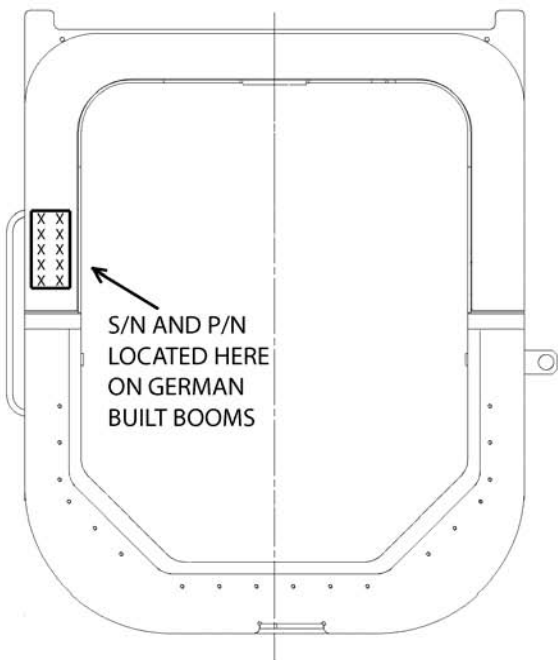

MEGAFORM Squareness

Checked By _____ Crane Model _____
 Date _____ Crane Serial # _____
 Distributor _____ In Service Date _____ Hourmeter _____

Boom Section Being Checked (i.e. Base, I/mid) _____
 Record Part Number of Boom Section _____
 Record Serial Number of Boom Section _____

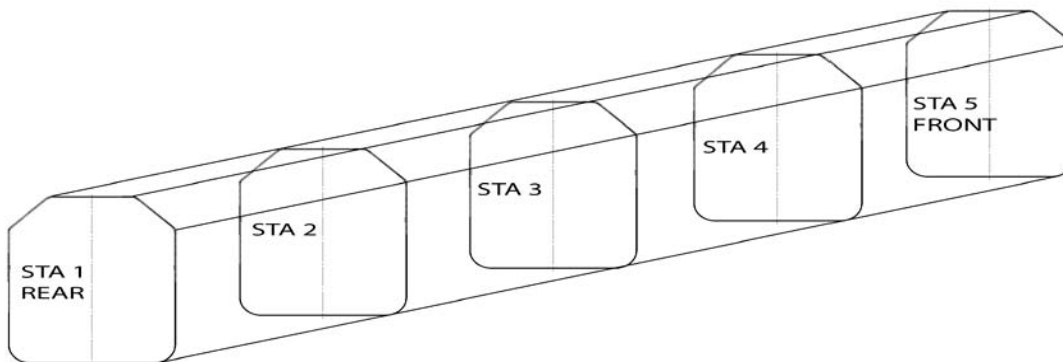

LEFT

RIGHT

Sta 1 _____	_____
Sta 2 _____	_____
Sta 3 _____	_____
Sta 4 _____	_____
Sta 5 _____	_____

1. With the boom lying on the top side, select 5 stations or intervals along the length of the boom. These will be where check dimensions are taken.
2. Starting at the rear (Sta 1) place the square across the top plate (bottom when flipped over) and protruding upward along side of the boom utilizing (3) gauge blocks as shown.
3. Measure the distance between the square and the side of the boom at the bend where shown.
4. Record the check dimension on this form.
5. Repeat procedure for the other side, taking check dimensions at the same distance from the rear of the section where the dimensions were taken on the first side.

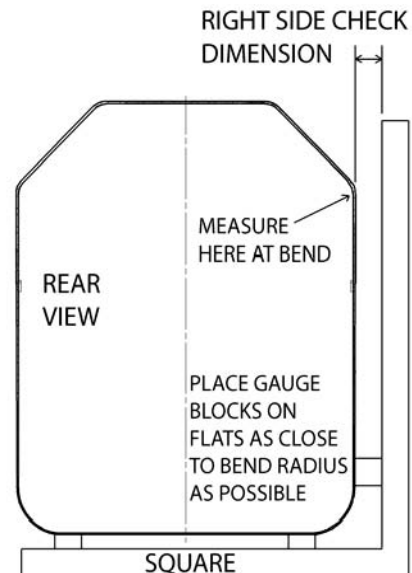

MEGAFORM Sweep

Checked By _____ Crane Model _____

Date _____ Crane Serial # _____

Distributor _____

Boom Section Being Checked _____

Record Part Number of Boom Section _____

Record Serial Number of Boom Section _____

Record Length of Boom Section _____

1. Place the gauge blocks against the side plate of the section, as close to the bend radius as possible, as shown on the sketch.
2. Draw the string tightly over the gauge blocks.
3. Measure the thickness of the gauge blocks and record.

Gauge Block Thickness _____

4. Measure the distance between the string and the side of the boom at various points along the string and record the maximum check dimension.

Left Side Max Check Dimension _____

5. Now measure the distance from the rear of the boom section to where the maximum check dimension was found and record below.

Left Side Dimension Location from Rear of Section _____

6. Repeat this procedure for the other side of the boom section and record the dimensions below.

Right Side Max Check Dimension _____

Right Side Dimension Location from Rear of Section _____

7. To obtain a true sweep measurement, one side will be greater than the gauge block thickness and the other side will be less than the gauge block thickness.

8. The sweep must be uniform throughout the entire length of the boom section and free of any kinks or deviations.

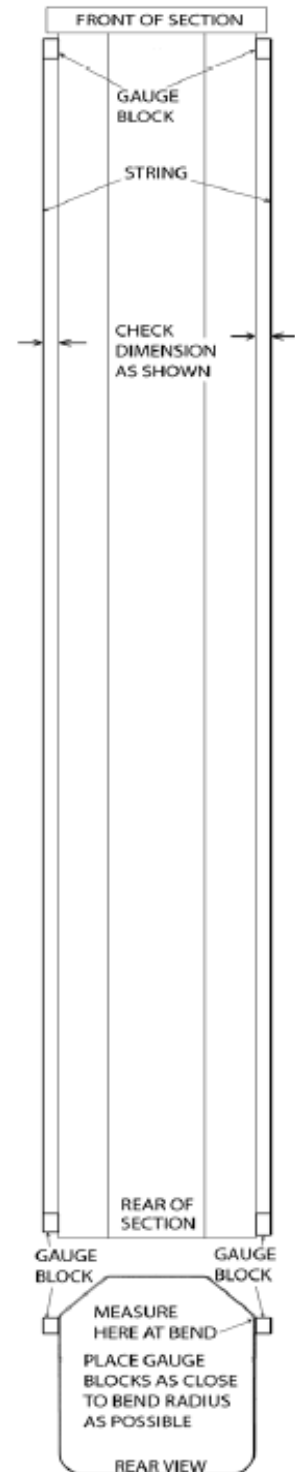

MEGAFORM Camber

Checked By _____ Crane Model _____
Date _____ Crane Serial # _____
Distributor _____

Boom Section Being Checked _____
Record Part Number of Boom Section _____
Record Serial Number of Boom Section _____

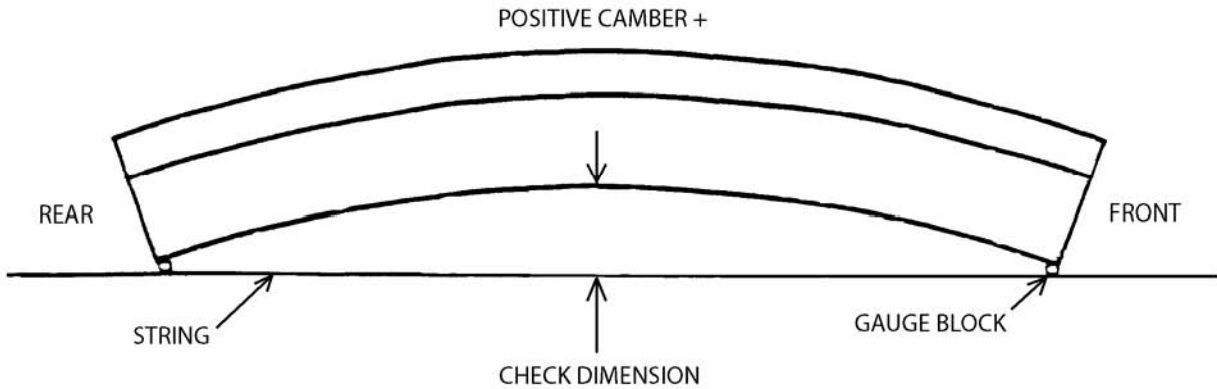

Record Camber Dimension Left Side _____

Record Camber Dimension Right Side _____

Record Distance from Rear to Max. Check Dimension Left Side _____

Record Distance from Rear to Max. Check Dimension Right Side _____

Record Thickness of Gauge Blocks _____

1. Lay boom on its side.
2. Place gauge blocks on top plate as close to the bend radius as possible at each end and pull string tightly over them.
3. Measure the distance between string and top plate at various points between both gauge blocks.
4. Record maximum check dimension.

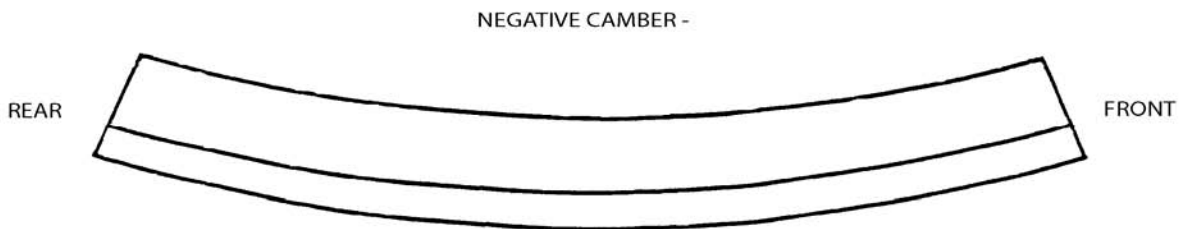

MEGAFORM Twist

Checked By _____ Crane Model _____
Date _____ Crane Serial # _____
Distributor _____

Boom Section Being Checked _____
Record Part Number of Boom Section _____
Record Serial Number of Boom Section _____
Record Width of Boom Section _____

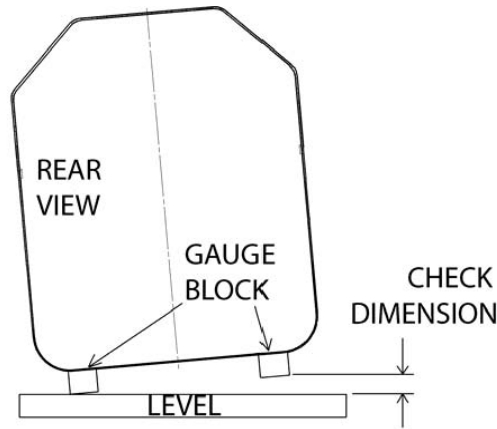

Record Check Dimensions as Twist _____

Record Side on which Twist was recorded _____

Twist Shown Above is on the Right Side

1. Place the boom bottom up.
2. Place gauge block on the top plate as close to the bend radius as possible. Then place a level across the gauge blocks at the rear and level the boom.
3. Once the rear is level, take the 4' level to the front of the boom and place it across the top plate utilizing the same gauge blocks used in the rear.
4. Lift either end of the level, one way or the other until the bubble is level.
5. Now measure the distance between the level and the gauge block and record that dimension on this form as twist.
6. To determine the direction of twist, stand at the rear looking toward the front. If you measured the distance between the level and the bottom rail on the left side of the boom, then record LEFT. If the check dimension was taken on the right side, then record RIGHT.
7. Record the direction of twist on this form.

MEGAFORM Concave/Convex

Checked By _____ Crane Model _____
 Date _____ Crane Serial # _____
 Distributor _____

Boom Section Being Checked _____
 Record Part Number of Boom Section _____
 Record Serial Number of Boom Section _____

Record Gauge Block Thickness _____

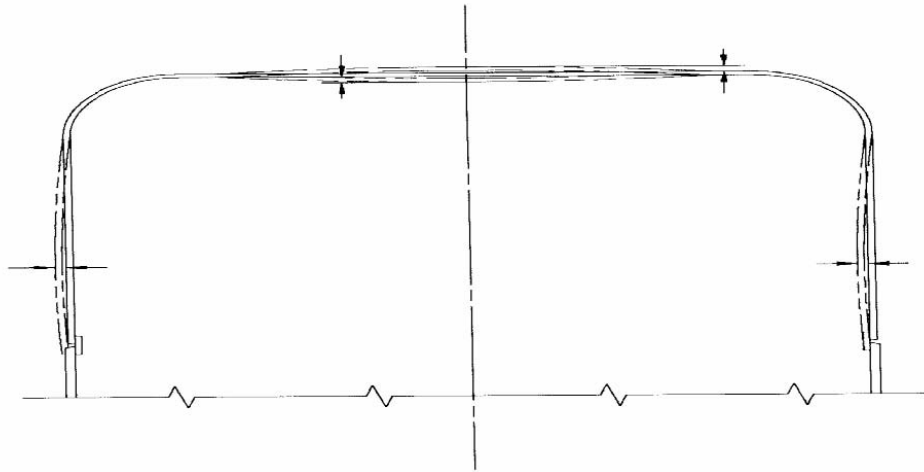

Left Side	Right Side	Top Plate
1 _____	1 _____	1 _____
2 _____	2 _____	2 _____
3 _____	3 _____	3 _____
4 _____	4 _____	4 _____
5 _____	5 _____	5 _____
6 _____	6 _____	6 _____
7 _____	7 _____	7 _____
8 _____	8 _____	8 _____
9 _____	9 _____	9 _____
10 _____	10 _____	10 _____
11 _____	11 _____	11 _____
12 _____	12 _____	12 _____

1. To check for concavity and convexity start at the rear of the section.
2. Check along the side plates and top plate of the section every 2 or 3 feet, recording any areas that visibly stand out as either concave or convex.
3. To measure, place the gauge blocks and string or straight edge perpendicular to the length of the section, locating the gauge blocks as close to the radius as possible.
4. If using a string, ensure that the string is pulled tight between the gauge blocks before measuring.
5. Measure the distance between the straight edge or string and the plate being measured. Measure at several points along the straight edge or string.
6. Record the dimension on this form.
7. If any dings, dents, creases or surface imperfections are noted during this inspection, please note them below.
